



Performance Installation Guide

Primo SL

PSL84

PSL104

Dear Customer,

For nearly five decades, Morel has been dedicated to engineering loudspeakers that redefine what's possible in mobile audio. The Primo SL continues this tradition, bringing our signature sound quality to places where space is limited but, performance cannot be compromised.

Designed from the ground up as a true shallow-mount solution, the Primo SL delivers deep, articulate bass with remarkable control—without requiring a large enclosure. Its advanced suspension system, efficient motor design, and carefully tuned acoustic profile provide the rich, musical low-frequency response Morel is known for, even in the most challenging installation environments.

We hope your Primo SL delivers years of enjoyment, transforming every drive with smooth, powerful bass that feels as good as it sounds.

If you need help with installation or system planning, your local authorized Morel retailer is ready to assist. You can also reach our support team at:

info@morelhifi.com

info@morelamerica.com

Dimensions

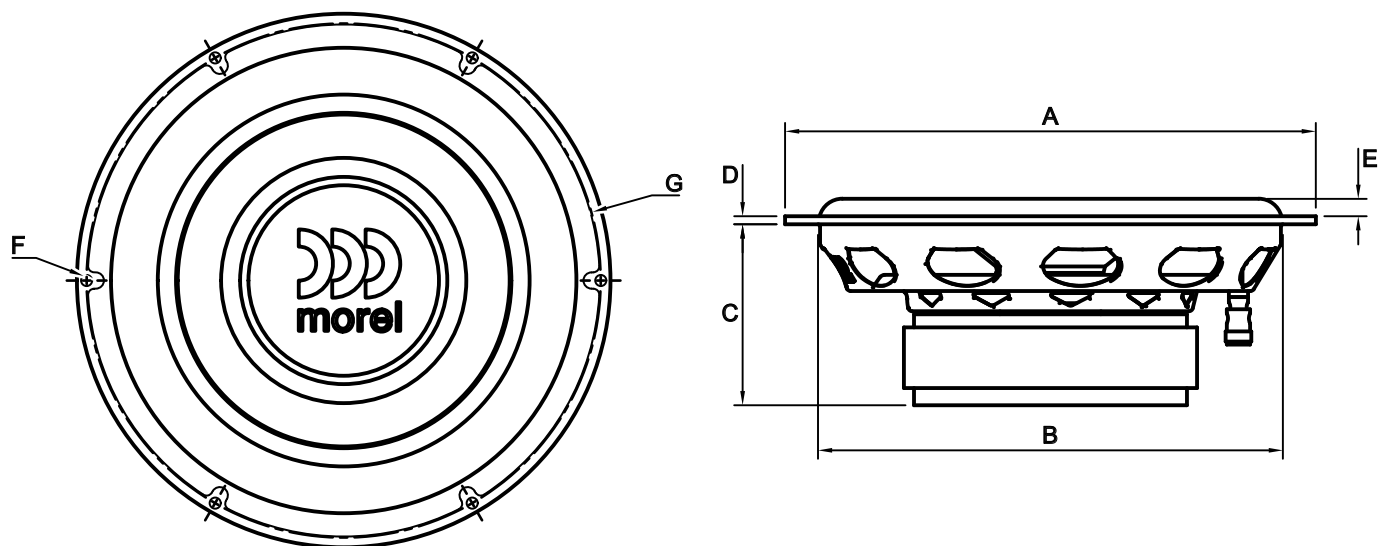

	PSL 804	PSL 104
A	8.74" (222 mm)	10.34" (262.6 mm)
B	7.16" (182 mm)	9.13" (232 mm)
C	2.75" (69.9 mm)	3.52" (89.5 mm)
D	0.16" (4.0 mm)	0.16" (4.0 mm)
E	0.34" (8.7 mm)	0.5" (12.6 mm)
F	0.17" (4.5 mm)	0.22" (5.5 mm)
G	8.4" (212.7 mm)	9.96" (253 mm)

Recommended Power

MODEL	MINIMUM	MAXIMUM
PSL 804	125 w	250 w
PSL 104	150 w	300 w

Voice coil wired in parallel (1-2 woofers)

4 Ω
Load

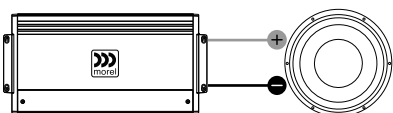

2 Ω
Load

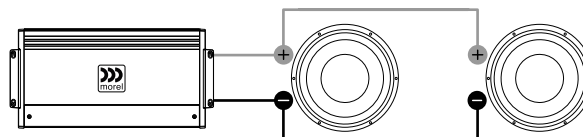

Voice coil wired in series (1-2 woofers)

4 Ω
Load

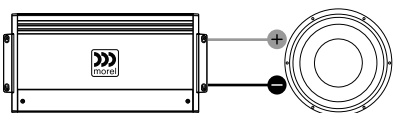

8 Ω
Load

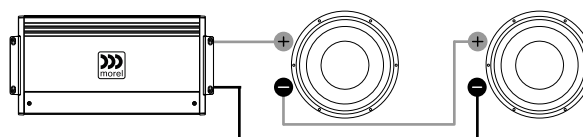

Enclosure Recommendations

The Primo SL subwoofers are engineered to deliver outstanding performance in both vented (ported) and sealed enclosures, giving you the flexibility to optimize your system for the space and sound you want. Choosing the right enclosure depends on your goals: if you're looking for the strongest overall output and the most dynamic low-frequency extension, a vented enclosure is the preferred choice. If vehicle space is limited and a compact design is necessary, a sealed enclosure will provide excellent control, accuracy, and smooth, natural bass in a smaller footprint.

Below are the recommended enclosure designs for the Primo SL series. These configurations are optimized to achieve a balanced, linear in-car bass response while ensuring reliable power handling and long-term performance. For custom enclosure designs—including multi-subwoofer systems or unique vehicle constraints—please reach out to the Morel technical team at info@morelamerica.com or tech@morelamerica.com

Enclosure Construction Guidelines

Use 3/4" (1.9 cm) or thicker MDF (Medium Density Fiberboard) when building the enclosure, and be sure to seal all joints with silicone to maintain an airtight seal. For improved rigidity and to minimize panel vibration, interior bracing is strongly recommended. A simple and effective method is to install triangular braces between each large, unsupported panel. When adding internal bracing, the displacement of these braces must be accounted for in the net internal air volume, as the recommended enclosure dimensions do not include bracing displacement.

Port Clearance Recommendations

Do not position the port opening against any solid surface, such as an internal brace, back panel, vehicle trunk wall, seat, or other interior surface. The port opening must remain completely unobstructed to perform properly.

To ensure this, take the smallest internal dimension of the rectangular port (P1 in our enclosure designs) and multiply it by 1.5. This number represents the minimum distance the port opening should be from any solid surface.

Custom Enclosure Designing

If you are designing your own enclosure, refer to the recommended airspace ranges in this manual for best performance. Following the optimal design will result in the most efficient use of space and maximize sound quality.

Note: Enclosures with less airspace than recommended may negatively affect low-frequency extension and power handling.

All airspace measurements listed in this manual already include the displacement of the subwoofer.

Port Displacement Calculation (for Vented Enclosures)

For vented enclosures, the displacement of the port must also be calculated and added to the internal airspace to determine the total (gross) enclosure volume.

Most commonly, a rectangular port is used for ease of construction. If calculating the displacement of the port:

1. Account for port wall thickness between the width (W) and height (H) dimensions. Example, if using 3/4" (1.9 cm) MDF, add this thickness where applicable.

2. Multiply:

$$\text{Width} \times \text{Height} \times \text{Length} = \text{Port Volume in in}^3$$

3. Convert the result to cubic feet:

$$\text{Port Volume (ft}^3\text{)} = \frac{\text{in}^3}{1728}$$

4. Add the port volume to the subwoofer's required airspace to determine the gross total enclosure volume.

Recommended (Vented) Ported Enclosure

MODEL	VOLUME NET	PORTED	TUNED TO
PSL 84	0.35 cuft 9.9 L	W 4" x H 1.125" x L 33.59" W 101.6mm x H 28.57mm x L 853.2mm	31Hz
PSL 104	0.7 cuft 19.8 L	W 6.5" x H 1" x L 33.2" W 165mm x H 25.4mm x L 843.3mm	27 Hz

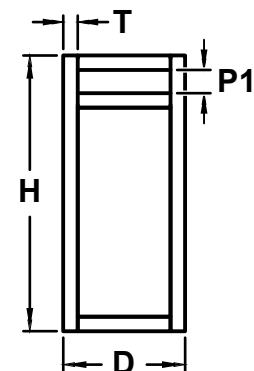
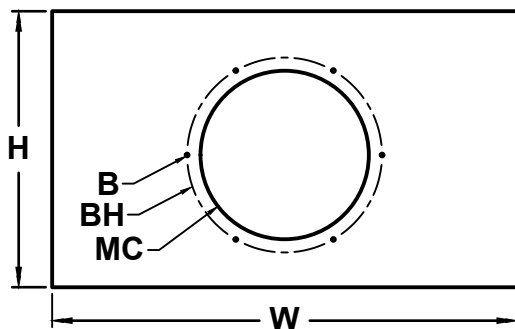
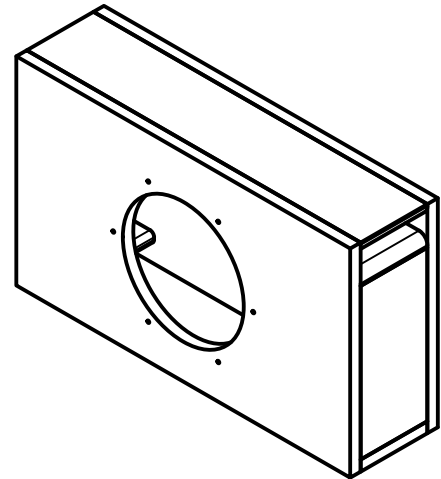
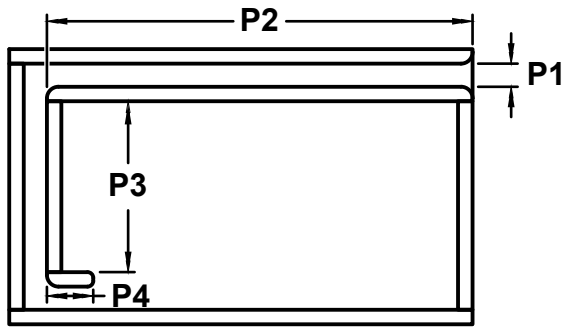

	PSL84	PSL104
H	12.5" (317.5mm)	14.5" (368.3mm)
W	20.75" (527mm)	20.5" (520.7mm)
D	5.5" (139.7 mm)	6.5" (165.1mm)
MC	Ø7.125" (181mm)	Ø9.1" (231.2 mm)
BH	Ø8.38" (213mm)	Ø9.9" (253mm)
B	6x Ø0.125" (3.18mm)	6x Ø0.125" (3.18mm)
P1	1.125" (28.57mm)	1" (25.4mm)
P2	18.875" (479.43mm)	18.75" (476.25mm)
P3	7.25" (184.15mm)	9.5" (241.3mm)
P4	3.71" (94.2mm)	1.45" (36.8mm)
T	0.75" (19mm)	0.75" (19 mm)

* Images of the enclosures are for reference only and may not accurately represent the actual shape or dimensions.

★★ Please note that enclosure volumes are provided as net internal volumes. Any internal bracing must be added to the net internal volume. If building a vented (ported) enclosure, be sure to add the total displacement of the vent including the construction materials used within the enclosure.

Recommended Sealed Enclosure

MODEL	VOLUME NET	F3
PSL 84	0.35 cuft 9.9 L	50Hz
PSL 104	0.55 cuft 15.6 L	44Hz

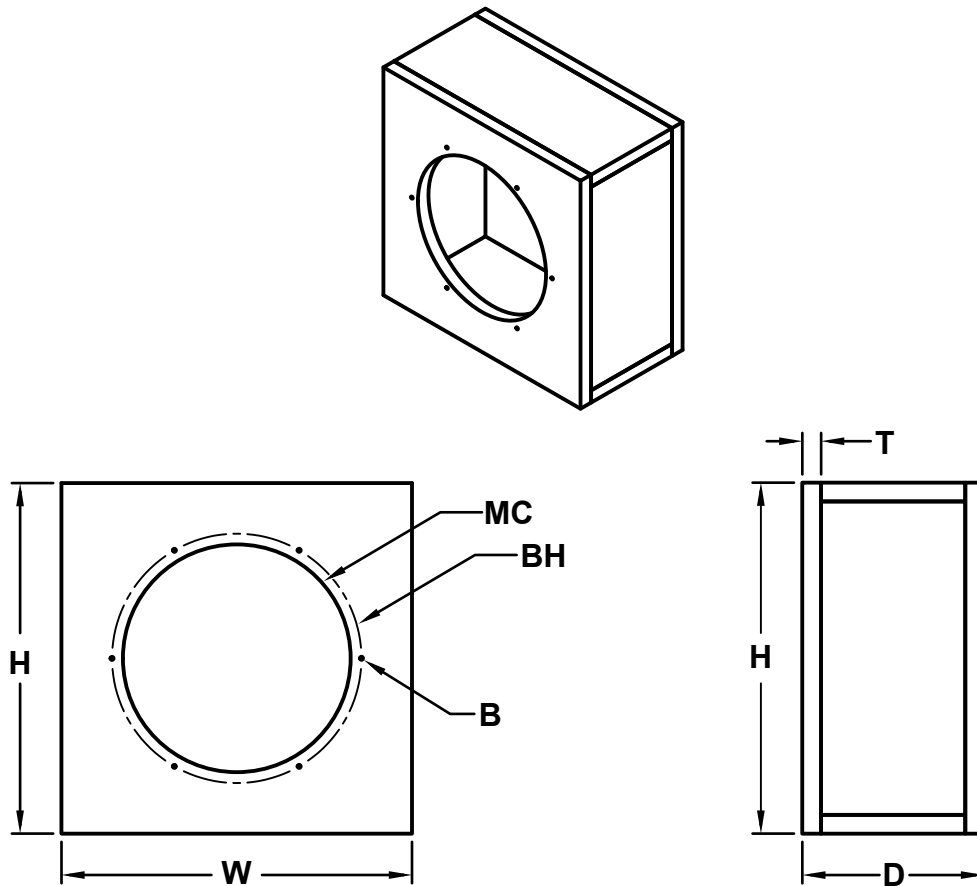

	PSL84	PSL104
H	11.5" (292.1mm)	14.25" (362mm)
W	13.75" (349.3mm)	17" (431.8mm)
D	5" (127mm)	5" (127mm)
MC	Ø7.25" (184mm)	Ø9.1" (231.2mm)
BH	Ø8.38" (213mm)	Ø9.9" (253mm)
B	6x Ø0.125" (3.18mm)	6x Ø0.125" (3.18mm)
T	0.75" (19mm)	0.75" (19mm)

* Images of the enclosures are for reference only and may not accurately represent the actual shape or dimensions.

** Please note that enclosure volumes are provided as net internal volumes. Any internal bracing must be added to the net internal volume. If building a vented (ported) enclosure, be sure to add the total displacement of the vent including the construction materials used within the enclosure.

Important Safety Warning

To ensure safe operation and protect both your audio system and your vehicle, please follow the safety guidelines below.

Continuous operation of an amplifier, speaker, or subwoofer at excessive volume—especially when the signal is distorted, clipped, or driven beyond its limits—can cause the system to overheat. This may lead to component failure, fire, or significant damage to your vehicle. Amplifiers must be installed with at least 4 inches (10 cm) of open space around them to maintain proper ventilation. Subwoofers should be mounted with a minimum of 1 inch (2.5 cm) of clearance between the front of the speaker and any nearby surface to ensure unrestricted cone movement and adequate airflow.

The Primo SL subwoofers are capable of producing very high sound pressure levels. Extended listening at elevated volumes can result in permanent hearing damage. If the audio becomes uncomfortable, harsh, or physically painful, reduce the volume immediately. Practicing responsible listening habits protects your hearing and ensures your system continues to perform safely and reliably.

Specifications

PRIMO SL	PSL 84	PSL 104
Overall Dimensions	8"	10"
Power Handling Wrms	250	300
Max. Trans. Pwr Handling Wrms	500	600
Sensitivity (2.83 V/1M) dB	84.6	86.4
Frequency response Hz	15-500	10-500
Resonance Freq. Fs Hz	39	30
Voice Coil Diameter mm (inch)	51 (2.0)	51 (2.0)
Voice Coil Height mm (inch)	29.2 (1.1)	29.2 (1.1)
Voice Coil Type/Former	Aluminium	Aluminium
Voice Coil Wire	Copper	Copper
DC Resistance (ohm) * VC in parallel	3.6	3.6
Voice Coil Induct. @1 kHz (mH)	1.6	1.9
Magnet System	Single magnet vented	Single magnet vented
HE-Magnetic Gap Height mm (inch)	8 (0.3)	8 (0.3)
BL Product/BXL	13.8	14.7
Max. Linear Ex./Xmax mm (inch)	±10mm (0.3)	±10mm (0.3)
Electrical Q Factor QES	0.59	0.58
QTS	0.53	0.52
QMS	4.96	5.02
Moving Mass MMS - gr/os	136.7 (4.8)	180.1 (6.3)
Equiv. Can Air Load VAS - L (cu.ft ³)	9.3 (0.33)	26.3 (0.93)
Effective Piston Area SD sq.cm (sq.inch)	220 (34.4)	347 (53.8)
Cone Type	Shallow design cone	Shallow design cone
Cone Material	Carbon fiber	Carbon Fiber
Unit Diameter mm(inch)	222 (8.74)	262 (10.3)
Mounting Depth mm (inch)	69.9 (2.75)	89.4 (3.5)
Mounting Cutout	182 (7.16)	232 (9.13)

★ Morel is constantly developing new technology and processes to improve its products. Morel reserves the right to modify specifications or change product design without notice.

Wishing you many years of sound enjoyment!



Morel, Ness Ziona, 70400 Israel.
Tel: +972-8-9301161
Fax: +972-8-9301312
E-mail: info@morelhifi.com

Morel America, Chandler, AZ, USA
Toll-free number: 1-877-667-3511
Fax: 1-718-721-1560
E-mail: info@morelamerica.com

www.morelhifi.com